

Convertible Stand Drive System for fast changeovers utilizing existing roll units

Many older convertible stand designs are **difficult and time consuming to convert** from the Horizontal to Vertical orientation (or from V to H). This problem can be rectified in a cost effective manner by replacing the problematic drive system while retaining the roll units, motor and, in some cases, the vertical gearbox.

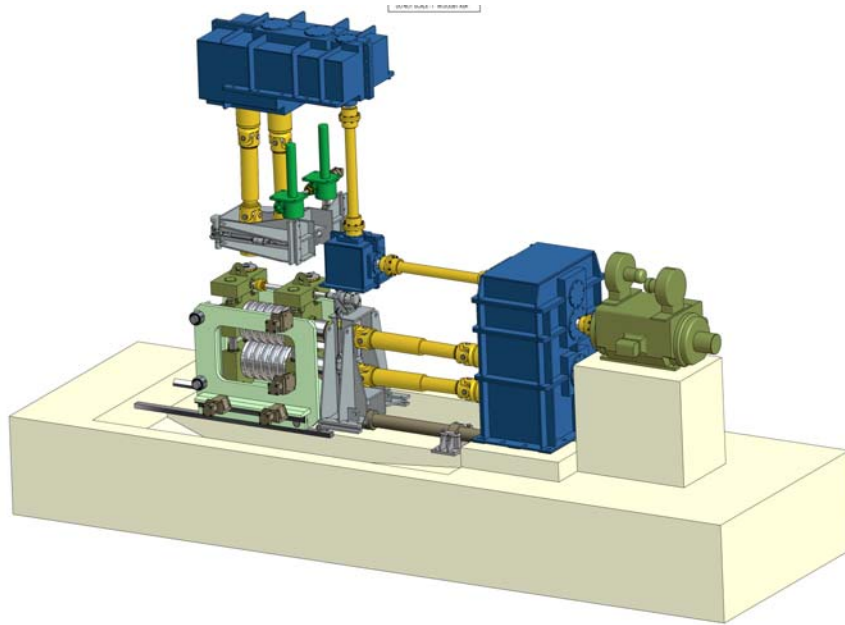

The convertible drive system design uses dedicated horizontal and vertical gearboxes and spindles to eliminate the need to tilt the entire stand. The existing central gearbox lubrication system can be reused or dedicated gear lube units for each gearbox can be added.

The system uses the same main mill motor and gearbox ratio, so no major Speed Control Automation changes are required.

Convertible stand with steel support tower removed for clarity

The **cost is reduced** by reusing existing mill components. Reusing the **roll units** results in a significant savings, as the roll units, rolls, guides, etc. can be used as-is. The supporting post can be reused with some modifications.

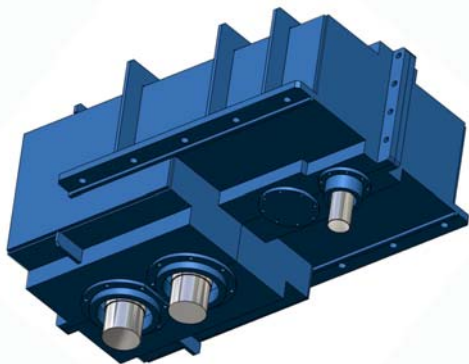

Other components such as the **vertical gearbox** can often be reused. Mounting everything on a steel tower makes the installation simpler and faster.

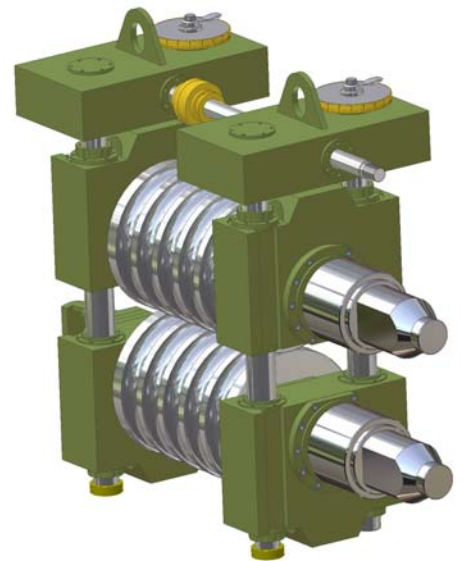

Convertible Stand Drive System for fast changeovers utilizing existing roll units

In the horizontal mode, the horizontal pass-change cylinder pulls the roll unit and supporting post assembly until it is engaged with the horizontal mill spindles. The mill spindles are set to the desired roll-center distance by adjusting the horizontal spindle support.

In the vertical mode, the horizontal pass-change cylinder pulls the roll unit and supporting post assembly until it is engaged with the vertical-tower mill-base rails. It is then raised up to the vertical spindles by overhead screw jacks. The mill spindles are set to the desired roll center distance by adjusting the vertical spindle support.

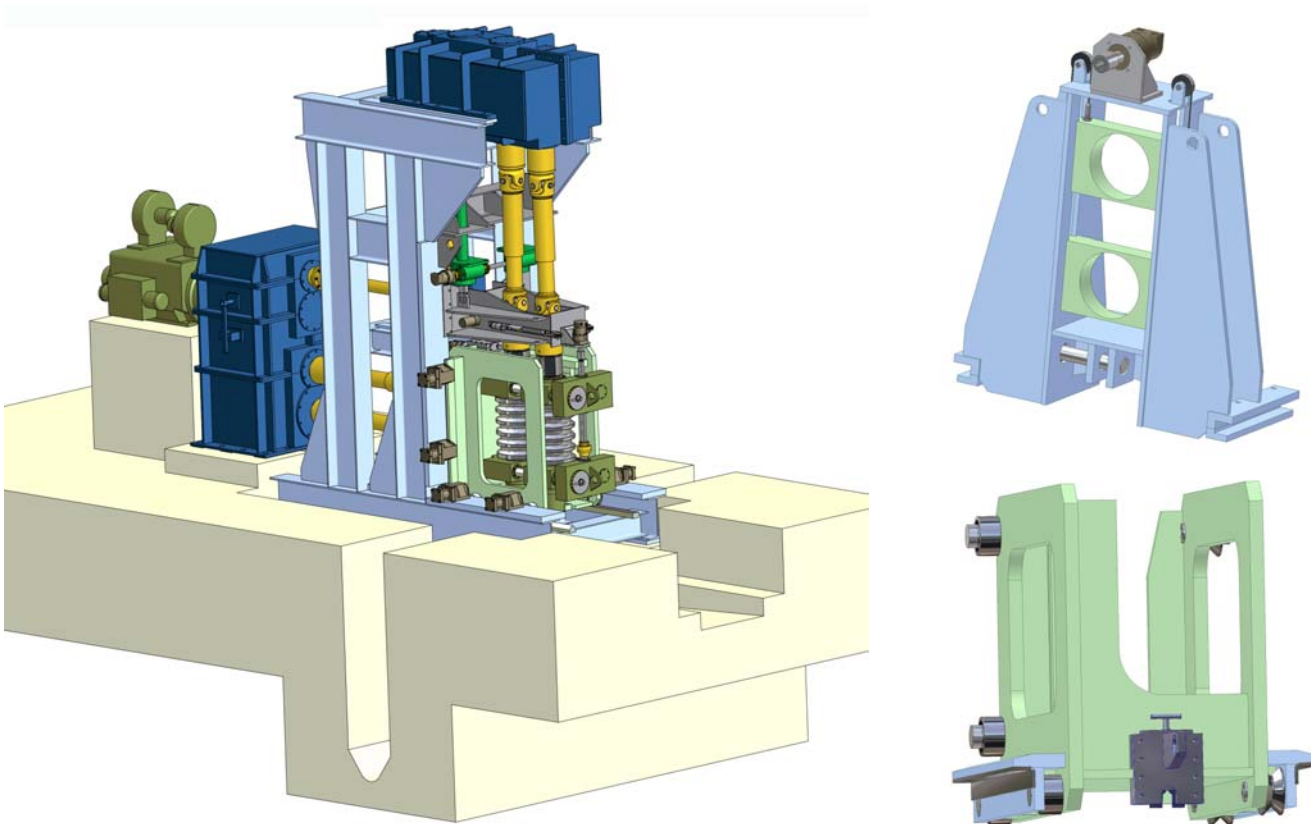

The horizontal and vertical mill stand clamps are identical: hydraulic disengagement and spring-loaded engagement.

Mills with a quick stand-change system can utilize the existing stand-change controls and tracks. The roll unit and supporting post assembly is pushed up to the stand by the existing stand-change system, where the horizontal pass-change cylinder takes the roll unit and supporting post assembly into the pass-line location.